

Feb. 20, 1951

J. RABINOW

2,542,430

AUTOMATIC REGULATION OF TIMEPIECES

Filed March 18, 1948

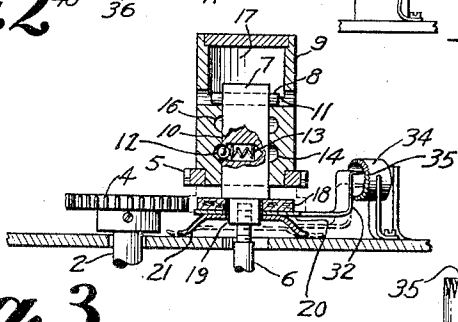
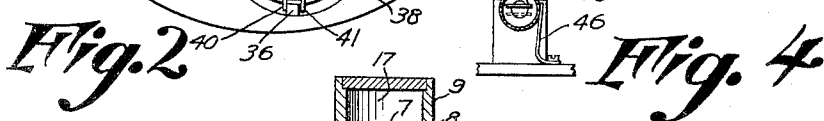
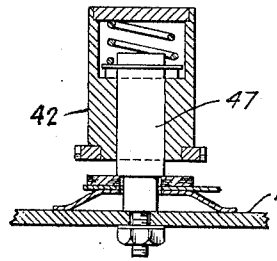
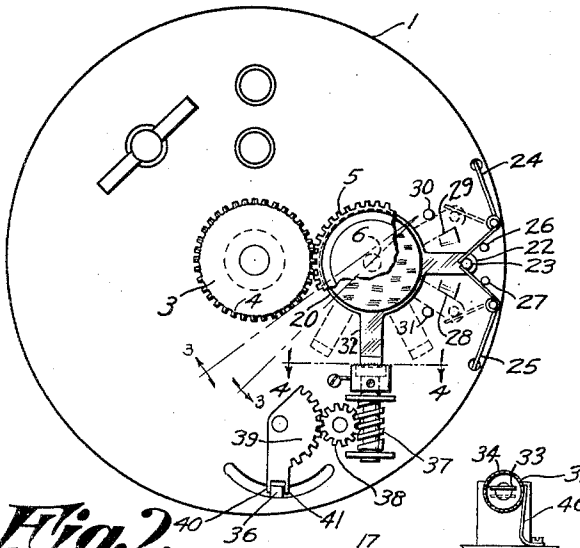
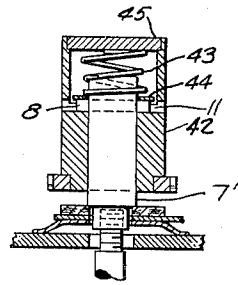
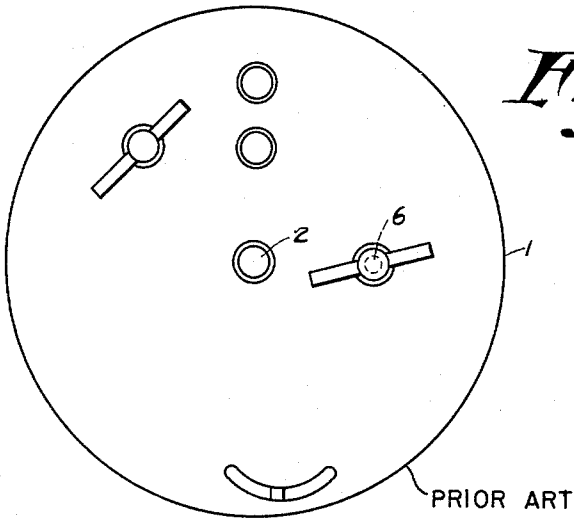

Inventor
Jacob Rabinow

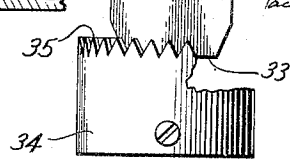

UNITED STATES PATENT OFFICE

2,542,430

AUTOMATIC REGULATION OF TIMEPIECES

Jacob Rabinow, Takoma Park, Md.

Application March 18, 1948, Serial No. 15,553

14 Claims. (Cl. 58-109)

1

My invention relates to timepieces such as watches and clocks, and has for its primary object the provision, in a timepiece, of means for automatically regulating the same solely by the recurrent act of setting the hands to the correct time, without any other adjustment or act of judgment by the user.

Attempts have been made to provide automatic regulation by the act of setting a timepiece, but all such prior attempts of which I am aware require some special adjustment by the operator, such as operating a control element to throw a special gear into operative association with the setting mechanism when it is desired that the time setting operation shall also effect the regulating operation; and some prior attempts have required in addition that the setting be performed at a certain time, e. g., exactly on the hour or at a certain hour. These aforementioned attempts have the great defect of requiring both a special mental effort and a physical act on the part of the user of the timepiece, and experience has shown that the average person will consider such acts too much trouble to perform consistently.

It is an object of my invention to require no judgment on the part of the user in keeping his timepiece properly regulated, and only the irreducible minimum action of occasionally setting the hands of the timepiece to the correct time, if, due to the well known perversity of mechanisms, it should manage to stray even slightly from the desirable ideal of perfect time-keeping.

Furthermore, if the timepiece has run down or, because of a change in time zone or for any other reason it becomes necessary to make a drastic manual change in the setting of the hands under conditions which do not necessarily imply inaccurate or incorrect regulation of the timepiece, it is an object of my invention, under such circumstances, to automatically disable and render ineffective my automatic regulating means, so as to reduce the likelihood of introducing an incorrect change in the regulation, and this, too, is accomplished without thought and without any extra effort or attention on the part of the user.

It is also an object to provide the above advantages with a minimum of structure, and with substantially no changes in the conventional construction, adjustment or manipulation of timepieces, other than the addition of a few simple elements.

With the above and other objects in view, which will become apparent as this description proceeds, my invention consists in certain fea-

2

tures of construction, combination and arrangement of parts and functions which will be described more fully below by way of example only with particular reference to the drawings, in which:

Fig. 1 is a rear elevation of clock, such as an ordinary alarm clock, which is to be modified in accordance with my invention.

Fig. 2 is a rear elevation of the clock after being modified by the additional elements comprising my invention.

Fig. 3 is a sectional view taken along line 3-3 of Fig. 2.

Fig. 4 is a view taken along line 4-4 of Fig. 2.

Fig. 5 is a sectional view of a modification of the setting knob 9 shown in Fig. 3.

Fig. 6 is a sectional view of another modification of knob 9.

Figure 7 is an enlarged fragmentary view showing the details of the crown gear and the actuating pawl.

Fig. 1 depicts the back of an ordinary alarm clock contained in case 1 to which, by way of example, I shall show my invention applied, although it is obviously equally applicable to other types of timepieces such as watches. The usual center setting stem 2, is ordinarily in such clocks provided with a knurled nut enabling manual rotation of the stem 2 to set the hands of the clock in the conventional fashion. For a purpose hereinafter disclosed, I replace the conventional knurled nut with a gear 3, the upper edges of whose teeth are sharpened near the outer circumference of the gear, as shown at 4, to enable its teeth to engage more readily with the similarly sharpened teeth of gear 5 when the latter is depressed into engagement with gear 3 as will be later described.

The clock winding stem 6 is usually provided with a key enabling the clock to be conveniently wound. I extend this stem 6 by the addition of stem 7. Pin 8 passes through and is fixed to the winding stem 7. About stem 7 is fitted a knob 9 having a bore 10 which fits on stem 7 but permits ready relative sliding or rotating motion between knob and stem. The projecting ends of pin 8 engage two recesses 11 in knob 9 to restrain the knob against both upward movement and rotation relative to stem 7 in the position shown in Fig. 3, the knob being held in the position shown by the click mechanism consisting of the ball 12 and the spring 13. The ball 12 fits into annular groove 14 thus holding the sleeve in the position shown. Thus, in the position shown in Fig. 3, rotation of knob 9 will rotate winding stem

3

7 to wind the clock in the usual fashion. The knob 9 may be knurled to facilitate winding, or may be provided with a key or bow for additional leverage if the force of the winding spring requires it, or may have both.

If the knob is depressed, a "click" will first be felt as the detent moves out of groove 14. Further depression will cause gear 5 to engage setting gear 3. When the two gears are fully engaged, as shown by dotted lines in Fig. 3, ball 12 will fall into groove 15 with a second "click," which will help to define the "setting" position, although the detent need not necessarily be made sufficiently strong to hold the knob in the lower position, or it may be so made, if desired, like the stem of an ordinary watch. In this lower position knob 9 is disengaged from winding stem 7 and is engaged with the setting stem 2 since pin 8 is free to revolve in the cavity 17 in the knob 9; and in this lower position the knob 9 also actuates an automatic regulating mechanism which will be described below.

A friction washer 18 loosely fits reduced portion 19 of stem 7 and is fixed to control disc 20 which is also loosely disposed about reduced portion 19 and rests lightly on spring washer 21. Control disc 20 has a projection 22 provided with a pin 23 by which this disc is normally held by springs 24 and 25 in a center position between the two springs as located by the two stops 26 and 27; the far ends of the springs are fixed to the back of clock 1. In the upper position of knob 9, rotation of the knob 9 (and stem 7) does not affect the above described group of loose washer-like members, and particularly does not affect control disc 20 which is held in its normal central position by springs 24 and 25.

When knob 9 is depressed into its lower position, the bottom of the knob engages friction washer 18, and force is transmitted through the stacked members 18 and 20, flattening spring washer 21 and depressing control disc 20, as shown by dotted lines in Fig. 3. If knob 9 is now rotated, washer 18 provides sufficient friction between the bottom of knob 9 and the top of control disc 20 so that the control disc rotates with the knob 9 against the centering force of spring system 24, 25. The springs are very lightly loaded, as their only function is to center the control disc when there is no force on it, i. e., when knob 9 is in the upper position. Note that projection 22, if sufficiently displaced from its initial angular position, will ride up on one of catches 28 or 29 (depending on the direction of displacement) until it falls behind the struck-up portion of the catch and is retained thereby between the catch and one of stops 30 or 31 against return to its original center position until knob 9 is released into its original position; at such time, spring washer 21 moves control disc 20 up to its original position so that projection 22 is raised above catch 28 or 29, and no force being now exerted by knob 9, control disc 20 is rotated back into its original position by the action of springs 24 and 25.

Integral with the control disc 20 which is made of thin flexible material is pawl 32, having a sharpened edge 33. In the initial position of Figs. 2 and 3 pawl 32 rests with edge 33 barely inside of, and slightly above the axis of, crown gear 34, which is provided with very fine teeth 35 arranged as shown in Figs. 3 and 4. The material of disc 20 is sufficiently flexible to permit pawl 32 to pass freely between teeth 35 when control disc 20 is rotated by knob 9 (this, of course, can happen only when disc 20 and knob

4

9 are in the lower position); if the pawl is resting on teeth 35 of the crown gear when the knob is subsequently released into the upper position, the pawl 32 will engage one of the teeth and carry it into the upper position under the force of spring washer 21 and so will rotate crown gear 34 with it a small fraction of a turn. After this has happened, the knob 9 separates from control disc 20, which rotates, as above described, back into its initial position.

Crown gear 34 drives the rate regulator 36 through a gear train shown as consisting of worm gear 37 fixed to the crown gear 34 and driving idler gear 38 which in turn drives gear sector 39 which actuates the regulator 36 by means of two fingers 40 and 41.

For certain applications it may be desirable not to use the two position click mechanism just described. Instead, the arrangement shown in Fig. 5 may be used. Here the knob 42 is arranged to slide along stem 7 as in Fig. 3 but in place of the click mechanism, spring 43 is provided inside the knob 42. A washer 44 rests on the ends of the pin 8 and the compression spring 43 is held between this washer 44 and the cover plate 45 of the knob 42. This spring 43 acts at all times to keep the knob in the position shown in Fig. 5 and the ends of pin 8 in the recesses 11. For winding the timepiece it is merely necessary to turn the knob 42. For setting the hands the knob is depressed against the force of the spring 43 until the gears 3 and 4 are fully meshed. This disconnects the knob 42 from the stem 7 as previously described. The spring 43 is made very weak so that a very mild manual force is required to slide the knob 42 along the stem 7.

It will thus be seen that with knob 9 in the initial or raised position, it can be used to wind the timepiece in the usual manner. By depressing knob 9 into its lower position, rotation thereof will set the hands of the timepiece through setting stem 2, and at the same time control disc 20 with pawl 32 will be first depressed, then rotated in one direction or the other, depending on whether the hands are to be set ahead or set back. Since the pawl can move between the teeth of crown gear 34, this gear is not affected by such rotation of the pawls. Replacing knob 9 to its initial position at the end of the setting operation will now, under certain conditions, cause a small correction in the regulation of the watch to be made, and the gear train 37, 38, and 39 is so arranged that this correction is in the proper direction. That is to say, if the timepiece was running fast, and should therefore be set back, the regulator will be altered in the proper direction to make the timepiece run more slowly thereafter, and vice versa. Note that the amount of this correction is very small, corresponding to a very fine adjustment of the running rate; no attempt is made to make a full correction or a correction proportional to the magnitude of the error, as has been done in previous regulators. My reasons for doing this are explained below.

As far as I know all previous attempts at automatic regulation of watches employed proportional corrections, that is, the corrections in the rate occurring during any one single operation of the mechanism were greater or less as the correction in the indicated time was greater or less. While at first thought this would appear desirable, more careful consideration brings forth the fact that such proportional control is valueless unless the time elapsed from the last previous correction is a function of the correction. The

5

reason for this is as follows. Suppose a watch shows the correct time at a certain date. A month later it is found that the watch has gained two minutes and its hands are moved back to the correct time. In all of the previously known devices of the type being considered here, this results in a finite change in the rate of the watch. Suppose further that this is the exact amount of change necessary to completely correct the rate of the watch. If this same watch had been fast two minutes after running for, say, six months, the same correction of rate accomplished by moving the hands back two minutes would be incorrect by a large amount since the correction required would be only one-sixth of that in the previous case. This difficulty can be overcome by designing a special mechanism into the timepiece that automatically changes the rate correction depending on the elapsed time from the last previous correction, but such devices would be complicated, costly, and in view of my invention, unnecessary.

The fixed correction described previously will be made only if pawl 32 has not been rotated so far that it passes entirely through and beyond the teeth of the crown gear 34 into the position indicated in dotted lines in Fig. 2. Such extreme motion will correspond to a certain predetermined setting of the timepiece hands, which may be made to be, for example, ten minutes in the case of an inexpensive timepiece. When control disc 20 has been once moved into such extreme position, it will be retained there as previously explained, by catch 28 or 29 acting on projection 22, and will remain in that position until the setting operation is finished and knob 9 returned to its upper position. The knob 9, while depressed, can be rotated any desired amount; after disc 20 is latched into its extreme position there will simply be frictional slippage between the knob 9 and washer 18 as the knob continues its rotation. Stop 30 or 31 restrains the disc 20 against further rotation and also prevents the light springs 24 and 25 from being overstrained by such rotation. After this has occurred, when knob 9 is released, pawl 32 rises, but as it is not now in engagement with crown gear 34 the pawl moves back into its initial position after it has risen, and the regulation is not altered.

When manual adjustment of the rate is desired, this can be accomplished by rotating crown gear 34, which may be knurled for this purpose, if desired, and may also be provided with a spring friction brake 46 to hold the crown gear wherever last positioned.

The above described construction accomplishes the objects of my invention, as will be explained more fully below.

First, it will be seen that I have provided for a small constant correction to be made whenever the hands are set, provided the timepiece has not gained or lost more than a predetermined amount since the last setting. In the case of a good and well-made timepiece, this amount should be no more than, for example, five minutes. Since the timepiece will normally be set at rare intervals, or at the most, every two or three days, a good piece will rarely have strayed more than five minutes during this period. If it has, it probably needs attention from a watchmaker and this does not come within the purview of my invention, which is intended to correct only the small, normal variations which even a good piece inevitably experiences due to changes in temperature, normal wear, etc. If the first setting does not accomplish the full necessary correction, one

6

or more subsequent settings will inevitably ultimately bring the timepiece to the best rate of which it is capable.

It is important to point out that backlash in the gearing between the crown gear and the rate regulator may be advantageous in two ways. Consider first the application of my invention to a very fine timepiece. Suppose the piece is running slow and several setting operations are performed in succession in one direction. The backlash of the gears is then taken out and the rate finally brought to nearly the correct value. The next setting should theoretically be overcompensating, unless it was exactly enough to regulate the watch perfectly, which is most unlikely. The setting following this should be in the reverse direction. If the backlash is deliberately so proportioned that half of a reverse setting of the crown gear is taken up in the backlash, this last correction will have only half the normal effect and should bring the regulation even nearer to the optimum than any of the full steps.

In the case that it is not desired to control the amount of backlash, its presence will have no effect except to require one or two additional settings to effect the movement of the rate regulator. A consistent rate error would be thus eliminated. I would like to point out further that it may be desirable to deliberately introduce some play, or backlash, into the gear system so that time zone changes during travel should cause no change in rate and so that only several successive corrections of the time piece in one direction would produce changes in rate.

In any case, by using spring loaded gears, backlash can be entirely eliminated, if that is desired.

If the time piece shown in my drawings has been allowed to run down and stop completely, or when changing from one time zone to another, or when for any other reason a large change in the setting of the hands is necessary, this usually has no bearing on the accuracy of the timepiece, and I therefore provide means, as described, for completely disabling the automatic regulator in this event. Note that once the hands have been turned beyond the predetermined amount and the control disc 20 is held in its extreme position, further manipulation of the hands has no effect on the regulation until the knob 9 is moved back to the initial position. Since the entire operation corresponds closely to the usual and normal way of setting a watch, in which the stem is manipulated from the "wind" position to the "set" position, the ordinary habitual manner in which people set watches is all that is necessary for the proper operation of my invention.

The disabling feature described in the preceding paragraph may not be necessary in the case of the most inexpensive timepieces such as cheap clocks where frequent zone changes are unlikely, or where a single small rate correction can be overlooked. An accidental correction such as caused by the setting resulting from failure to wind the clock would be eliminated by a subsequent correction. To eliminate this disabling feature the bent-up detents 28 and 29 need not be provided.

The operation of my automatic regulator need not be confined solely to those timepieces where the setting knob is also used for winding the timepiece. The principle of my invention can be applied equally well to those timepieces where the winding is performed by a separate mechanism entirely. A modification of my invention

7

for such application is shown in Fig. 6 where the stem carrying the setting knob 42 is a member 47 rigidly attached to the clock case 1. The operation of the automatic regulation is exactly identical to that previously described. The winding of the clock in this case is performed by a separate shaft and has no bearing on my invention.

It will be apparent that my invention is equally applicable to watches as well as to the clock shown or to any other type of timepiece having rate adjusting means. In the case of a watch it would obviously be preferable to retain the usual relation of "wind" and "set" positions of the stem rather than the one shown; that is, the depressed or low position of the watch stem is usually the "wind" position, and the stem must generally be "clicked" into the elevated or upper position to set the watch. The exact arrangement of clutch and gearing to accomplish this depends somewhat on the watch mechanism employed, and will not be described here, as it is considered to involve only mechanical skill to broadly adapt my invention to the structure of any known timepiece, using the principles described above, and I therefore wish it to be understood that I do not consider my invention to be confined to the structural details shown, but I intend its scope to be indicated by the accompanying claims.

I claim:

1. A timepiece comprising time indicating means, control means for setting same to a desired value, rate regulating means for increasing and decreasing the running rate of the timepiece, adjusting means operably connected between the above control means and rate regulating means to change the adjustment of the said rate regulating means whenever said control means are operated; said change in adjustment being in a direction dependent upon the direction of the difference between the original reading of the said time indicating means and the subsequent reading to which the time indicating means are set, said adjusting means including means arranged to cause the said changes in the adjustment of said regulating means to be of a predetermined fixed amount.

2. The device described in claim 1 further including means operably connected to said control means, arranged and constructed to disable said adjusting means whenever said difference exceeds a predetermined amount.

3. A timepiece comprising time indicating means, setting means for setting same to any desired time indication, regulator means for increasing and decreasing the running rate of the timepiece, adjusting mechanism operably connected between said setting means and the said regulator mechanism, said adjusting mechanism arranged and constructed, upon normal operation of said setting means to change the setting of the time indicating means, to vary by a predetermined fixed amount the adjustment of the said regulator means in a direction determined solely by the direction of the difference between the initial reading of the time indicating means and the final reading after said setting operation is completed, said direction being such as to reduce the regulation error of the timepiece.

4. The timepiece as described in claim 3 further including means operably connected to the said setting means arranged and constructed to

8

disable said adjusting mechanism whenever said difference exceeds a predetermined amount.

5. A spring driven timepiece comprising time indicating means, rate regulating means settable in one direction to increase the rate and in the opposite direction to decrease the rate of the timepiece, control means movable into each of two positions and operable normally while in one of said positions to set the time indicating means, and adjusting means constructed and arranged to be actuated by the movement of said control means from said one position to the other position, said adjusting means further arranged to move said rate regulating means by a predetermined fixed amount in a direction controlled by the direction of setting of the time indicating means.

6. The timepiece as described in claim 5 further including means operably connected to said control means to automatically disable said adjusting means whenever said control means changes the setting of the time indicating means by more than a predetermined amount.

7. A timepiece comprising time indicating means, rate regulating means, settable in one direction to increase the rate and in the opposite direction to decrease the rate, control means having two positions and operable in one of said positions for setting the time indicating means, adjusting means actuated by movement of said control means from said one position to the other of said positions for moving said rate regulating means by a predetermined fixed amount in a direction controlled by the direction of setting of the time indicating means.

8. A timepiece comprising time indicating means, rate regulator mechanism for increasing and decreasing the running rate of the timepiece, a rotatable setting member for setting the position of said time indicating means either ahead or back at will, mechanical means connected between said setting member and said regulating means arranged and constructed to operate said regulating means toward rate correction whenever said member is rotated to correct the reading of said time indicating means, and means operably connected to the rotatable setting member whereby said mechanical connecting means moves said rate regulating means by a predetermined fixed amount during each said setting of the position of said time indicating means.

9. The timepiece as described in claim 8 further including means operably connected to said rotatable setting member and also to said mechanical connecting means for rendering ineffective said mechanical connecting means whenever the time indicating means are moved by said rotatable member more than a predetermined amount.

10. A spring driven timepiece, comprising time indicating means, rate regulating means including a movable adjusting member manually operated means having different positions for winding the said spring and for setting the time indicating means, cooperating means between said manually operated means and said rate regulating means whereby the rate of the timepiece is altered by a fixed amount during motion of said manually operated means from the setting position to the winding position, means for conditioning of said cooperating means by movement of said manually operated means from the winding to the setting position for subsequent movement of said adjusting member, and means for moving said adjusting member by a fixed amount to effect

said rate alteration, said last means being actuated by said motion of said manually operated means from the setting to the winding position.

11. In the timepiece as set forth in claim 10, disabling means cooperatively connected to the said manually operated means and arranged and constructed to prevent the said cooperating means from affecting the rate of the timepiece when the position of the said indicating means is changed by more than a predetermined amount.

12. A timepiece comprising time indicating means; rate regulating means movable in either of two directions to respectively increase or decrease the running rate of the timepiece; manipulatable means for setting said time indicating means to any desired time value, said setting means including a control element having a normal "non-setting" position and a "setting" position in which the timepiece is being set; a mechanical cooperating linkage between said setting means and said rate regulating means constructed and arranged to move said rate regulating means by a single fixed distance each time said linkage is operated; clutch means engageable by motion of said control element from "non-setting" to "setting" position to control operation of said linkage; said linkage being operated by motion of said control element from said "setting" to said "non-setting" position, the direction of motion of said rate regulating means being such as to increase the running rate of the timepiece when said indicating means are moved forward and vice versa.

13. The timepiece as described in claim 8 wherein the said mechanical cooperating linkage further includes means for disengaging said link-

age upon manipulation of said setting means to change the time indication by more than a predetermined amount.

14. A timepiece comprising time indicating means, control means for setting same to a desired value, rate regulating means for increasing and decreasing the running rate of the timepiece, adjusting means operably connected between the above control means and rate regulating means to change the adjustment of the said rate regulating means whenever said control means are operated; said change in adjustment being in a direction dependent upon the direction of the difference between the original reading of the said time indicating means and the subsequent reading to which the time indicating means are set, and means, operably connected to said control means, arranged and constructed to disable said adjusting means whenever said difference exceeds a predetermined amount.

JACOB RABINOW.

REFERENCES CITED

The following references are of record in the file of this patent:

UNITED STATES PATENTS

Number	Name	Date
721,361	Engwall	Feb. 24, 1903
731,819	Sibley	June 23, 1903

FOREIGN PATENTS

Number	Country	Date
6,444	Switzerland	Apr. 21, 1893
19,578	Great Britain	of 1897